

Questa realizzazione permette di trasportare prodotti ad alta temperatura, fino a 220°C (esecuzioni speciali per temperature superiori disponibili a richiesta). E' costruita con supporti in acciaio ed i cuscinetti sono alloggiati completamente all'esterno. Le tenute sono a premitreccia-premistoppa.

These valves allow the conveying of products with high temperature up to 220°C (special executions for temperatures above available on request). They are equipped with steel supports and the bearings are placed completely outside. They are fitted with packing glands.

Ces écluses permettent le transport de produits avec d'hautes températures jusqu'à 220°C (versions spéciales pour des températures supérieures disponibles sur demande). Elles sont construites avec des supports en acier et les paliers sont placés complètement à l'extérieur. Elles sont équipées avec presse-étoups.

Die Schleuse ist für den Einsatz bei Produkttemperaturen bis max. 220°C geeignet (Ausführungen für Temperaturen über 220°C auf Anfrage). Die Temperaturbeständigkeit wird durch außenliegende Lager in Stahl-Lagergehäusen sichergestellt, die Abdichtung erfolgt mittels Stopfbuchsen.



VPS/se

Supporti esterni per alte temperature
 External supports for high temperatures
 Supports extérieurs pour hautes températures
 Abgesetzte Lager für Hochtemperaturanwendungen

VALVOLA ROTATIVA
 ROTARY VALVE
 ÉCLUSE ALVÉOLAIRE
 SCHLEUSE

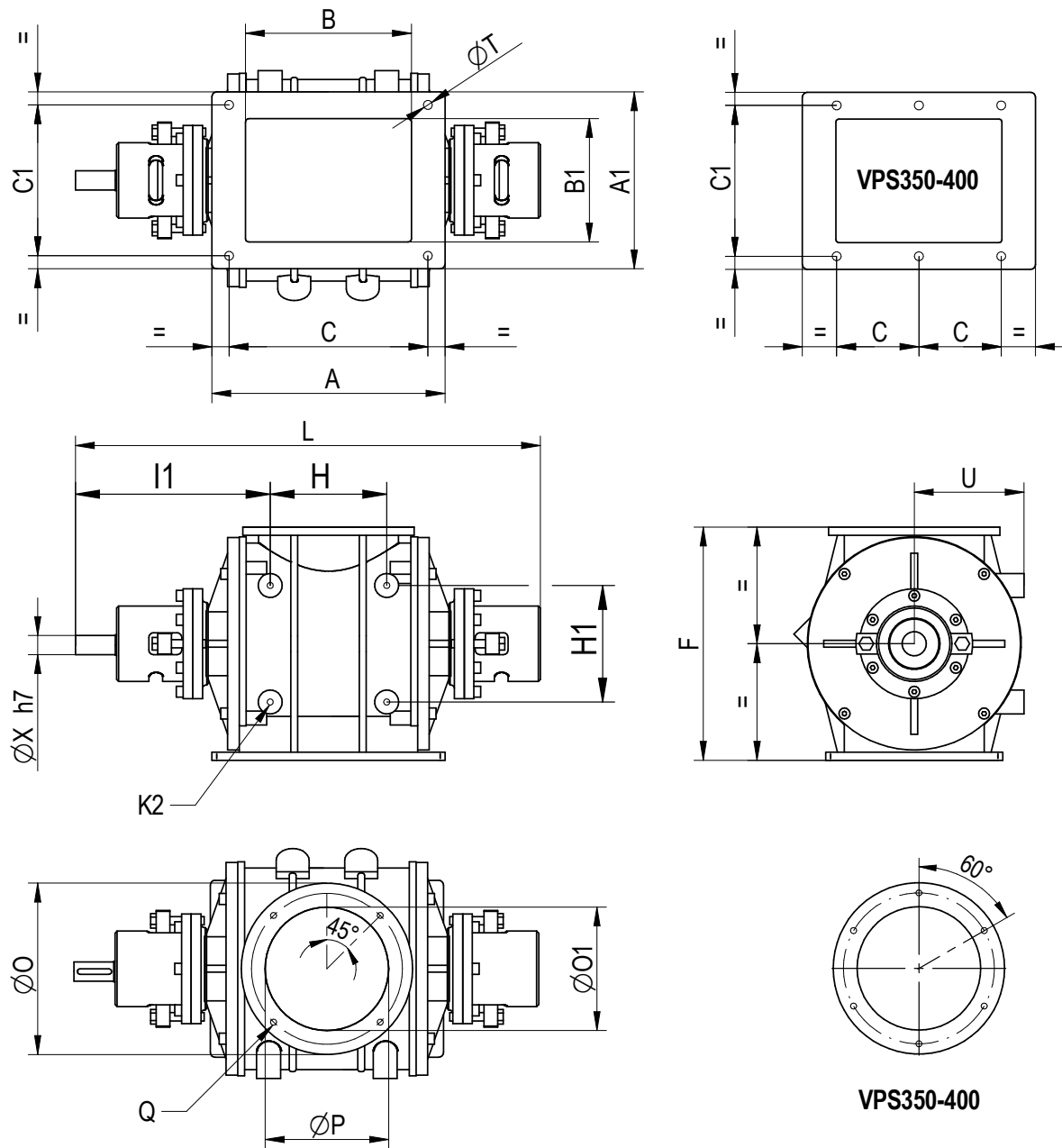

VPS350-400

TIPO TYPE TYP	A	A1	B	B1	C	C1	F	H	H1
VPS180	210	188	150	120	180	160	245	110	105
VPS230	256	218	185	148	220	185	310	120	120
VPS270	340	258	242	180	290	220	340	170	170
VPS300	372	310	266	218	330	270	382	200	185
VPS350	470	360	360	250	210	320	470	240	200
VPS400	490	410	400	320	145	380	527	250	250

TIPO TYPE TYP	I1	K2	L	Ø0	ØO1	ØP	Q	N° fori holes nr. N. trous Lochanzahl	ØT	N° fori holes nr. N. trous Lochanzahl	U	ØX
VPS180	253	M8	559	180	120	150	M8	4	10	4	112	24
VPS230	272,5	M10	603	210	150	185	M8	4	12	4	138	28
VPS270	285,5	M10	679	250	180	220	M10	4	13	4	160	28
VPS300	301	M12	740	300	220	260	M12	4	14	4	176	34
VPS350	326	M12	830	385	300	350	M12	6	14	6	222	34
VPS400	426,5	M12	1000	438	350	400	M12	6	16	6	255	54

Ci riserviamo di modificare le misure senza preavviso. We reserve the right to change any dimension without notice. Nous reservons de modifier les mesures sans préavis. Wir behalten uns das Recht vor die im Katalog angegebenen Abmessungen ohne Vorankündigung zu ändern.

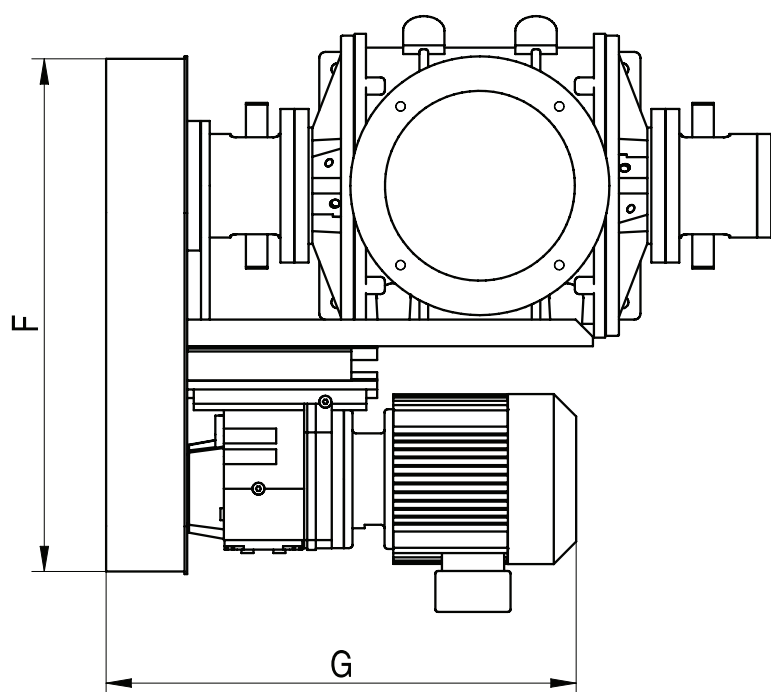
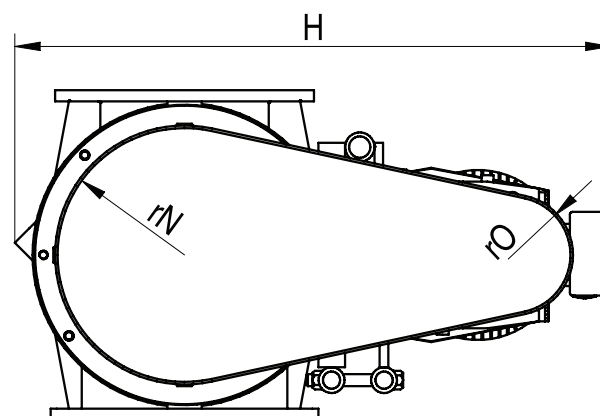
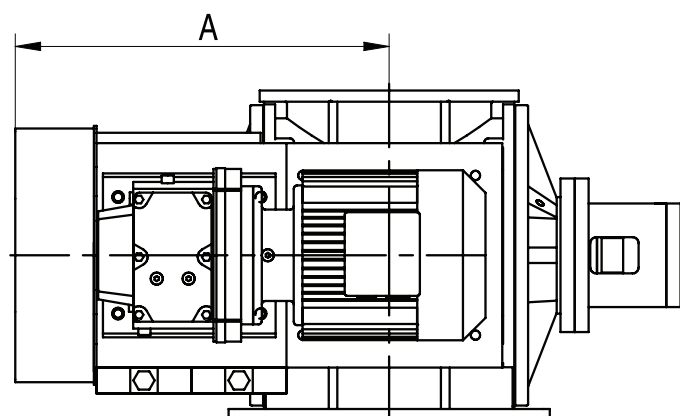

TIPO TYPE TYP	A	F*	G*	H*	rN	rO	PESO / WEIGHT / POIDS / GEWICHT [kg]	
							albero nudo bare shaft arbre nu freies Wellenende	trasmissione a catena with chaindrive transmission par chaîne Kettenantrieb
VPS180	334	420	431	507	95	72	40	63
VPS230	365	460	431	560	95	72	62	86
VPS270	405	507	490	593	120	72	92	130
VPS300	433	532	490	630	120	72	115	155
VPS350	508	594	524	775	117	72	200	273
VPS400	571	667	575	871	152	87	260	330

* Queste misure possono variare in base al tipo di motoriduttore adottato / These measures might change according to the type of the gearmotor
Ces dimensions peuvent changer selon le moto-réducteur employée / Diese Abmessungen sind abhängig vom verwendeten Getriebemotor und können abweichen.

Ci riserviamo di modificare le misure senza preavviso. We reserve the right to change any dimension without notice. Nous reservons de modifier les mesures sans préavis. Wir behalten uns das Recht vor die im Katalog angegebenen Abmessungen ohne Vorankündigung zu ändern.